

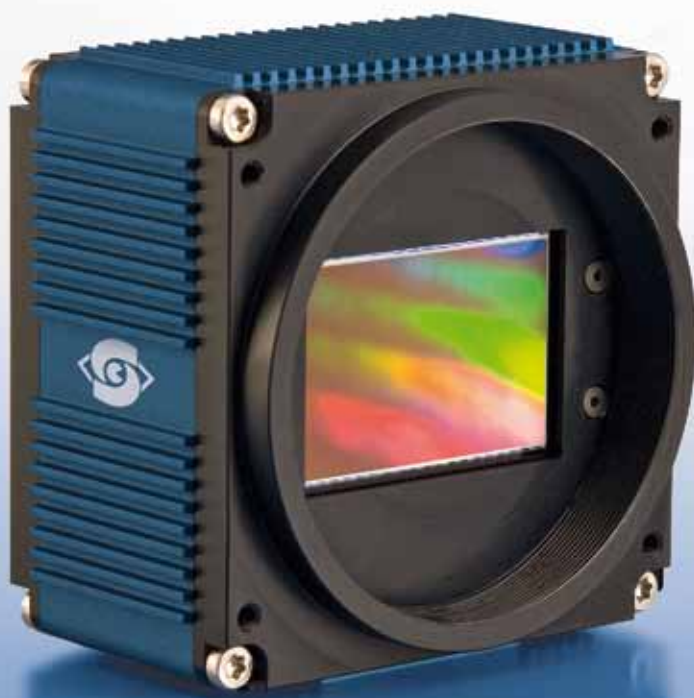

SVS-VISTEK

SVCam-HR

11, 16 and 29 Megapixel GigE VISION Cameras



International

 Scale your vision.

SVCam-HR

High Performance with High Resolution



The SVCam-HR series cameras provide the highest resolutions available for the most demanding machine vision applications. Equipped with the latest 2- and 4-tap Kodak interline transfer CCD sensors the HR series is available in monochrome and color versions with Camera Link (see separate folder) or Gigabit Ethernet interfaces.

Capturing a large field of view quickly and easily saves processing time and avoids costly mistakes. Typical application areas for these cameras are optical metrology, quality assurance, surveillance of large areas and traffic monitoring. The SVCam-HR camera series ensures the maximum performance required for these demanding applications.

With their cutting-edge electronics design and the use of dual- and quad-tap sensors the HR series cameras offer industry leading frame rates at extremely low noise levels. Sophisticated processing of the critical analog CCD video signal by Correlated Double Sampling (CDS) leads to significant noise reduction. Straight forward conversion into digital signals results in an excellent signal-to-noise ratio. Additionally, the integration of intelligent processing offers various modes for exposure time and trigger control settings. The compact housing allows installation even in limited space conditions.



Real value features: With the optionally available „Canon-Adapter“ you can control the focus and iris parameters of Canon „EF“ lenses directly from the camera.



Features with real value: Power your LED light directly from the HR series and use it as an innovative strobe controller.



The SVCam-HR series provides for quick return-on-investment for demanding imaging systems by delivering an unbeatable combination of image quality, performance, features and reliability in a compact package.

All camera models of the SVCam-HR series have the following features:

- > Progressive Scan CCD sensors
- > Monochrome and color versions (Bayer Pattern)
- > Various trigger (internal/external/free running) and exposure modes
- > Adjustable gain
- > Low offset
- > Various binning modes
- > Partial Scan
- > Optical interface M58, F-Mount optionally available
- > Operating temperature range from -10°C (non-condensing) to +45°C

GigE specific features:

- > GigE Vision (Gigabit Ethernet) standard compliant
- > Two parallel Ethernet connections in order to overcome speed limitations
- > 100/1000 MBit Ethernet interface
- > 14 Bit ADC with 8 or 12 Bits transferred
- > Area of Interest (AOI)
- > White balance for color versions
- > Strobe output, configurable delay
- > SDK for Windows and Linux available

Major advantages of GigE Vision

GigE Vision offers numerous hardware and software advantages for users over the entire range of industrial image processing applications. Most important of these advantages is that the hardware used can be easily and rapidly exchanged, thus shortening design cycles and reducing development costs.

- > Cost effective
- > Easy to interface
- > Wide range of „off the shelf“ industrial-standard plugs and cables up to class IP68
- > High bandwidth data transfer rate (120 MB/sec per Output)
- > Up to 100 m range without extra switch
- > Wide range of applications in image processing
- > Any desired number of devices can be connected to the host
- > Remote service capability

GigE Cameras

Camera Type	Resolution [Pixel]	Sensor Size	Frame Rate	Pixel Size [μm]	Housing Size [mm]	ADC Bit	Lens Mount
A svst1002	4.008 x 2.672	43.3 mm diag.	6.1 fps	9 x 9	70 x 71 x 52.7	14	M58/F-Mount
A svst16000	4.872 x 3.248	43.3 mm diag.	4 fps	7.4 x 7.4	70 x 71 x 52.7	14	M58/F-Mount
B hr16050*	4.920 x 3.288	32.36 mm diag.	10 fps	5.5 x 5.5	70 x 71 x 55	14	M58/F-Mount
B hr16070*	4.864 x 3.232	43.2 mm diag.	10 fps	7.4 x 7.4	70 x 71 x 55	14	M58/F-Mount
B hr29050	6.576 x 4.384	43.47 mm diag.	6.2 fps	5.5 x 5.5	70 x 71 x 55	14	M58/F-Mount

* Preliminary

A Connector pin-out

Dimensions [mm]

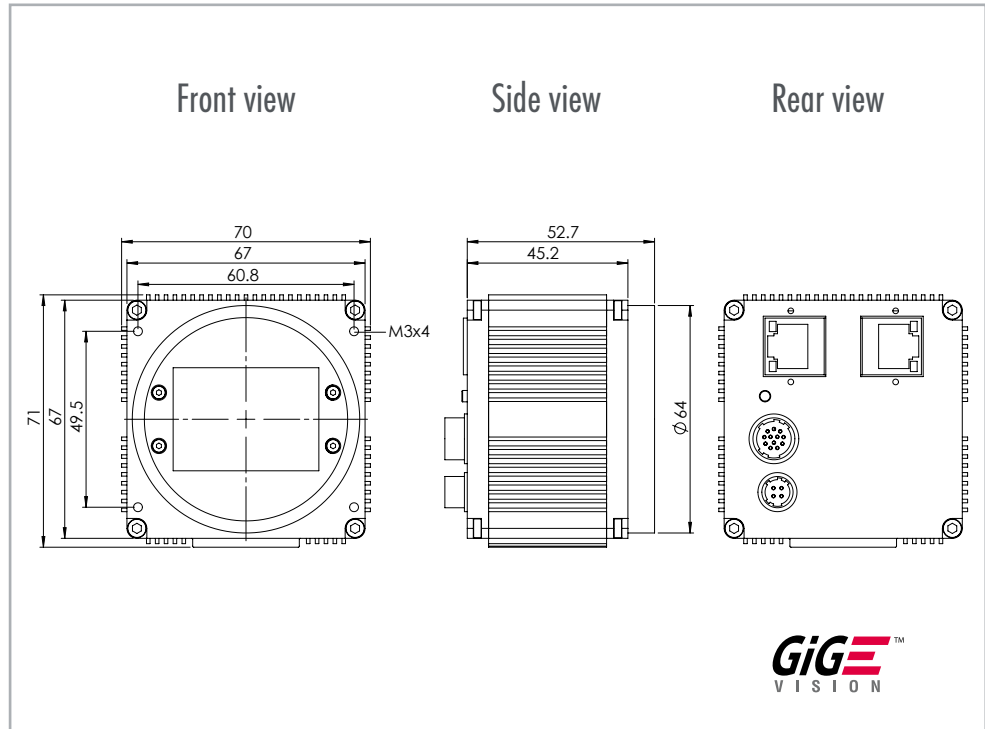
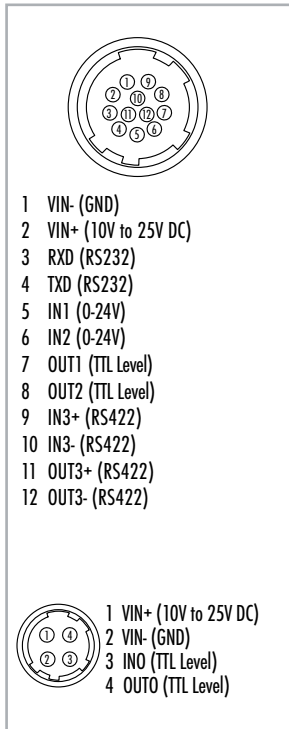

B Connector pin-out

Dimensions [mm]

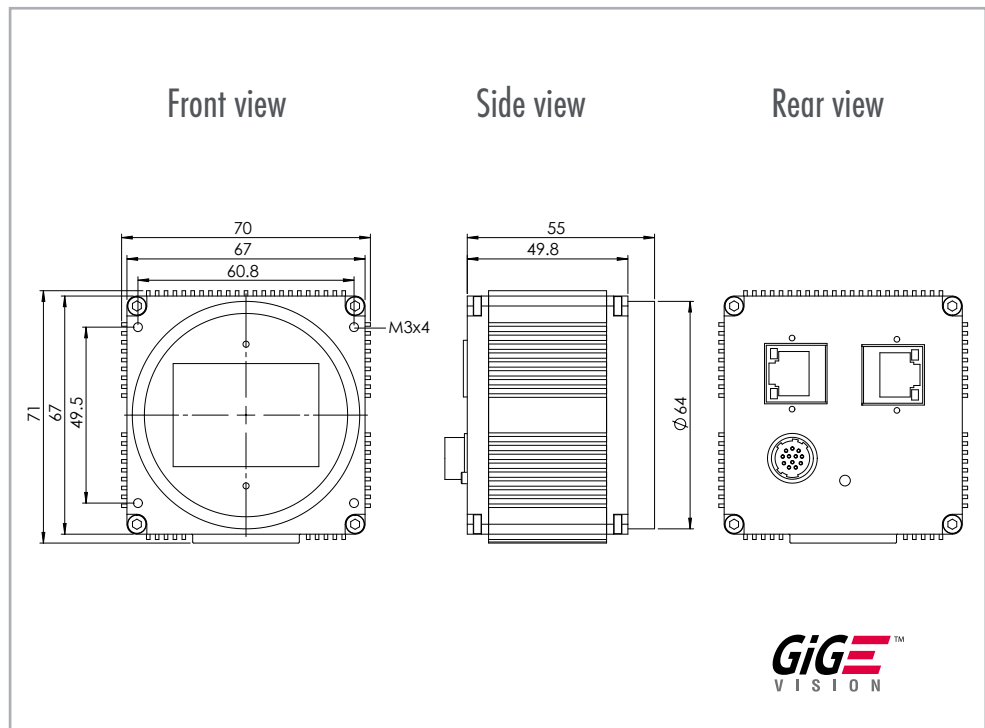
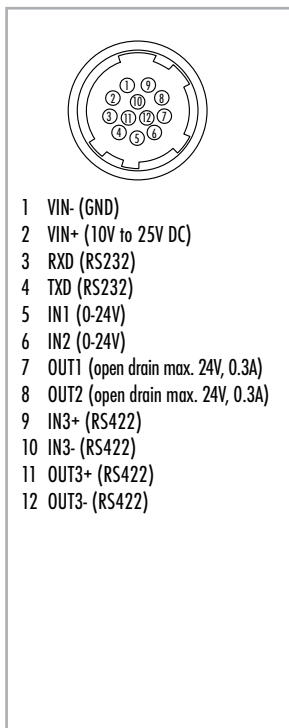

Application Areas

SVCam cameras are used successfully in a wide range of different industries, e.g.:

- > Aerospace
- > Automotive
- > Beverage
- > Food
- > Information
- > Mechanical engineering
- > Medical technology
- > Optical metrology
- > Pharmaceutical
- > Photovoltaic/power engineering
- > Plastics
- > Printing
- > Semiconductor
- > Timber
- > Traffic monitoring
- > Transportation systems



SVS-VISTEK

SVS-VISTEK GmbH

Muehlbachstrasse 20
82229 Seefeld
Germany

Tel. +49-(0) 81 52-99 85-0
Fax +49-(0) 81 52-99 85-79
info@svs-vistek.com
www.svs-vistek.com

SVCam – High-performance CCD cameras made by SVS-VISTEK

“SVCam” stands for high-performance CCD cameras developed and manufactured in modular designs which can be tailored to meet specific customer requirements. In total there are currently five camera series, representing state-of-the-art camera technology which match the specific needs of our customers:

SVCam-ECO

Maximum performance with a minimum of size. Cost-effective Gigabit Ethernet camera series for your applications.

SVCam-EVO

The Masterpiece of camera engineering. Combines high resolution with the highest level of speed. DualGigE- or Camera Link-output available. A very unique set of features to maximize flexibility and benefits.

SVCam-CF

Diversity and flexibility with Gigabit Ethernet or Camera Link interfaces. Coverage of the most popular CCDs in order to suit all of your applications.

SVCam-HR

Maximum resolution, yet smallest design possible. With Gigabit Ethernet and Camera Link interfaces for those applications requiring absolute precision.

SVCam-SLC

Slim, right-angle housing allowing access to space limited applications. This very unique GigE Vision camera series will open up new opportunities.

Supported Interfaces



For more information our sales team will be pleased to assist you with expert advice. Please contact us.